

# 8-Step-Sequencer

Gate & StepMix Options

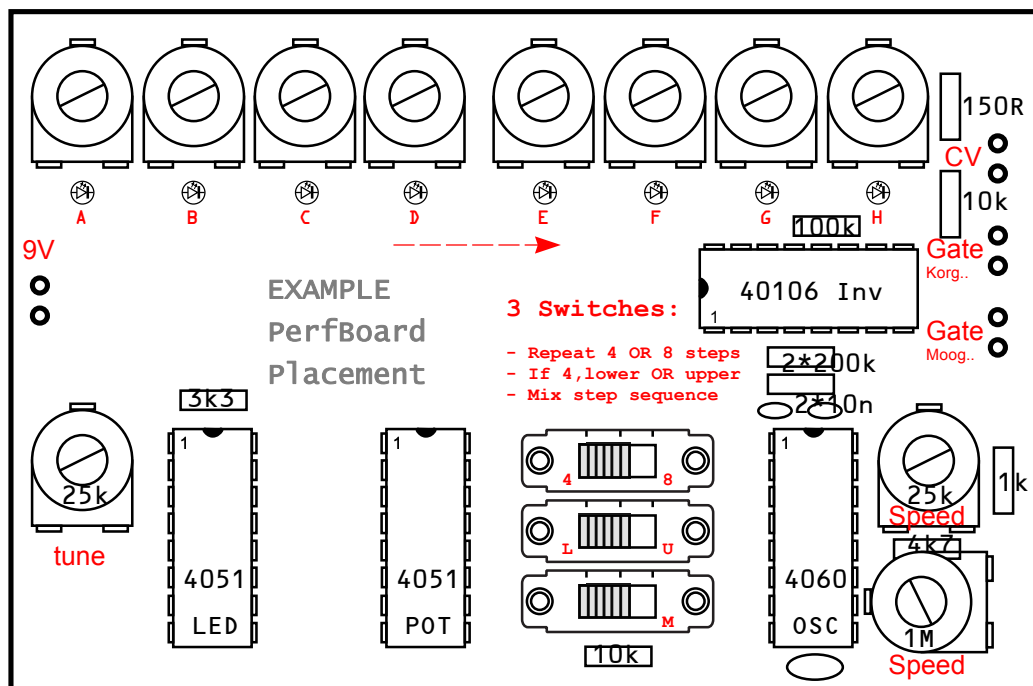

- 10 x 10k..25k lin Pot
- 1 x 10k lin Pot tune
- 1 x 1M lin Pot
- 2 x 200k\*
- 1 x 100k\*\*
- 2 x 10k\*\*
- 1 x 3k3 LED limit
- 1 x 4k7 Ri
- 1 x 1k
- 1 x 150R Limit
- 2 x 10n Ceramic\*
- 1 x 560pF Ceramic
- 2 x 1N4148 Diode\*
- 10 x LED 2mA
- 1 x 4060 CMOS
- 2 x 4051 CMOS
- 1 x 40106 CMOS\*
- 3 x T217 Double pole\*\* changover switch